

## 1 Multiple Choice

1.1 NAT allows multiple hosts to share the same IP address in a way that conforms to the E2E principle.

1.2 Port numbers are used to multiplex among hosts behind the same NAT.

1.3 Which protocol does a host use to learn its own IP address?

- (a) DHCP
- (b) DNS
- (c) ARP
- (d) ICMP
- (e) None of these

1.4 Which protocol does a host use to learn its own MAC address?

- (a) DHCP
- (b) DNS
- (c) ARP
- (d) ICMP
- (e) None of these

1.5 Which protocol does a host use to learn the MAC address of another host on the same network?

- (a) DHCP
- (b) DNS
- (c) ARP
- (d) ICMP
- (e) None of these

1.6 DHCP is a protocol in which of the following layers?

- (a) Physical            (d) Transport
- (b) Datalink           (e) Application
- (c) Network

1.7 ARP is a protocol in which of the following layers?

- (a) Physical            (d) Transport
- (b) Datalink           (e) Application
- (c) Network

1.8 Which of the following can a host learn with DHCP? Select all that apply.

- (a) Its own MAC address.
- (b) Its own IP address.
- (c) The MAC address of another host.
- (d) The IP address of another host.
- (e) The IP address of its first-hop router.
- (f) The MAC address of its first-hop router.
- (g) Its own subnet mask.

## 2 Host-to-Host

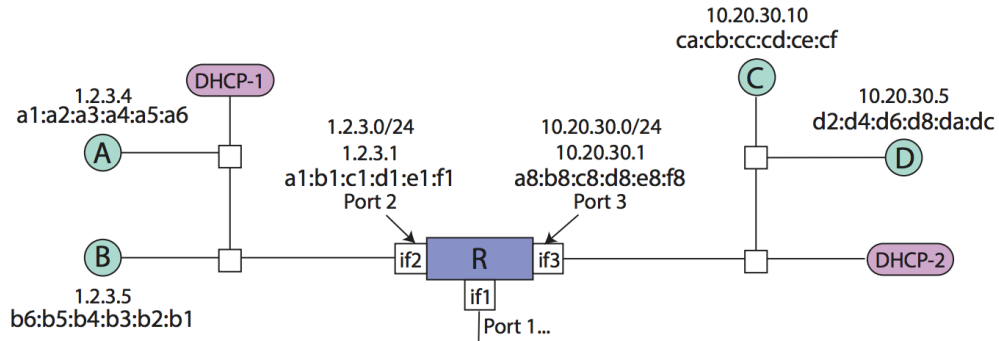

Consider the above topology. Here, two networks are connected through router *R*. *R* has three interfaces, each associated with a port, MAC address, IP address, and subnet.

We are going to consider what happens when *A* sends a packet to *C*. Assume that *A* just attached to the network, but already knows the IP address of *C* (10.20.30.10). No hosts or routers have sent any previous ARP requests.

- 2.1 First *A* needs to learn its own IP address, subnet mask, and the IP of its first-hop router by using DHCP. For each of the following DHCP messages, indicate the message's timing in the packet exchange (1 is first, 4 is last), who sends the message, and whether the message is broadcast or unicast.

Message	Order	Sender	Message Type
DHCP request			
DHCP ACK			
DHCP discovery			
DHCP offer			

- 2.2 Using this information, how does *A* determine if *C* is on the same subnet?

- 2.3 Given that  $C$  is not on the same subnet as  $A$ ,  $A$  must send the packet to its first hop router  $R$ . Which requests and responses are exchanged before this can happen?

<b>Request</b>	<b>Response</b>
ARP request for 1.2.3.4	ARP response: 1.2.3.4
ARP request for 1.2.3.1	ARP response: 1.2.3.1
ARP request for 10.20.30.10	ARP response: 10.20.30.10
ARP request for a1:a2:a3:a4:a5:a6	ARP response: a1:a2:a3:a4:a5:a6
ARP request for a1:b1:c1:d1:e1:f1	ARP response: a1:b1:c1:d1:e1:f1
ARP request for ca:cb:cc:cd:ce:cf	ARP response: ca:cb:cc:cd:ce:cf

- 2.4 Is the ARP request broadcast or unicast? What about the ARP response?

- 2.5 In the packet  $A$  now sends to  $R$ , what are the source and destination IP and MAC addresses?

- 2.6 How does  $R$  know which interface to forward  $A$ 's packet on?

- 2.7 Now  $R$  has the packet. List all remaining packets that are exchanged until  $C$  receives the packet from  $A$ .

- 2.8 What are the source and destination IP and MAC addresses for the packet that  $R$  sends to  $C$ ?

**Source IP:**

**Source MAC:**

**Destination IP:**

**Destination MAC:**

### 3 Network Address Translation

Consider a host A behind a NAT, trying to communicate with a remote host B. When a packet headed for B leaves host A, its source port is 56789, destination port is 443, source IP is 192.168.1.10, destination IP is 8.8.8.8. When a packet headed for A leaves host B, its source port is 443, destination port is 60000, source IP is 8.8.8.8, destination IP is 203.0.113.5. Based on the information above, answer the following questions:

- 3.1 The packet from host A to host B arrives at the NAT. What are the fields in the packet after the NAT has altered it?

Source IP:

Source Port:

Destination IP:

Destination Port:

- 3.2 The packet from host B to host A arrives at the NAT. What are the fields in the packet after the NAT has altered it?

Source IP:

Source Port:

Destination IP:

Destination Port: